

Hardware/Software co-design experience for onboard satellite navigation receiver

A. Dion¹ (arnaud.dion@isae.fr)

E. Boutillon², V. Calmettes¹, E. Liegeon³

¹Université de Toulouse, ISAE, ²Lab-STICC, ³Thales Alenia Space

Context

- **Validation** of a new **methodology** for Thales Alenia Space.
- Space Constraints:
 - radiation, power, life of the satellite...
- Applications:
 - telecom, image processing, **GNSS**
- Actual methodology:
 - Almost **no reusing, no flexibility, design break.**
- New requirements:
 - **flexibility, seamless** design flow, design **productivity.**

Design flow

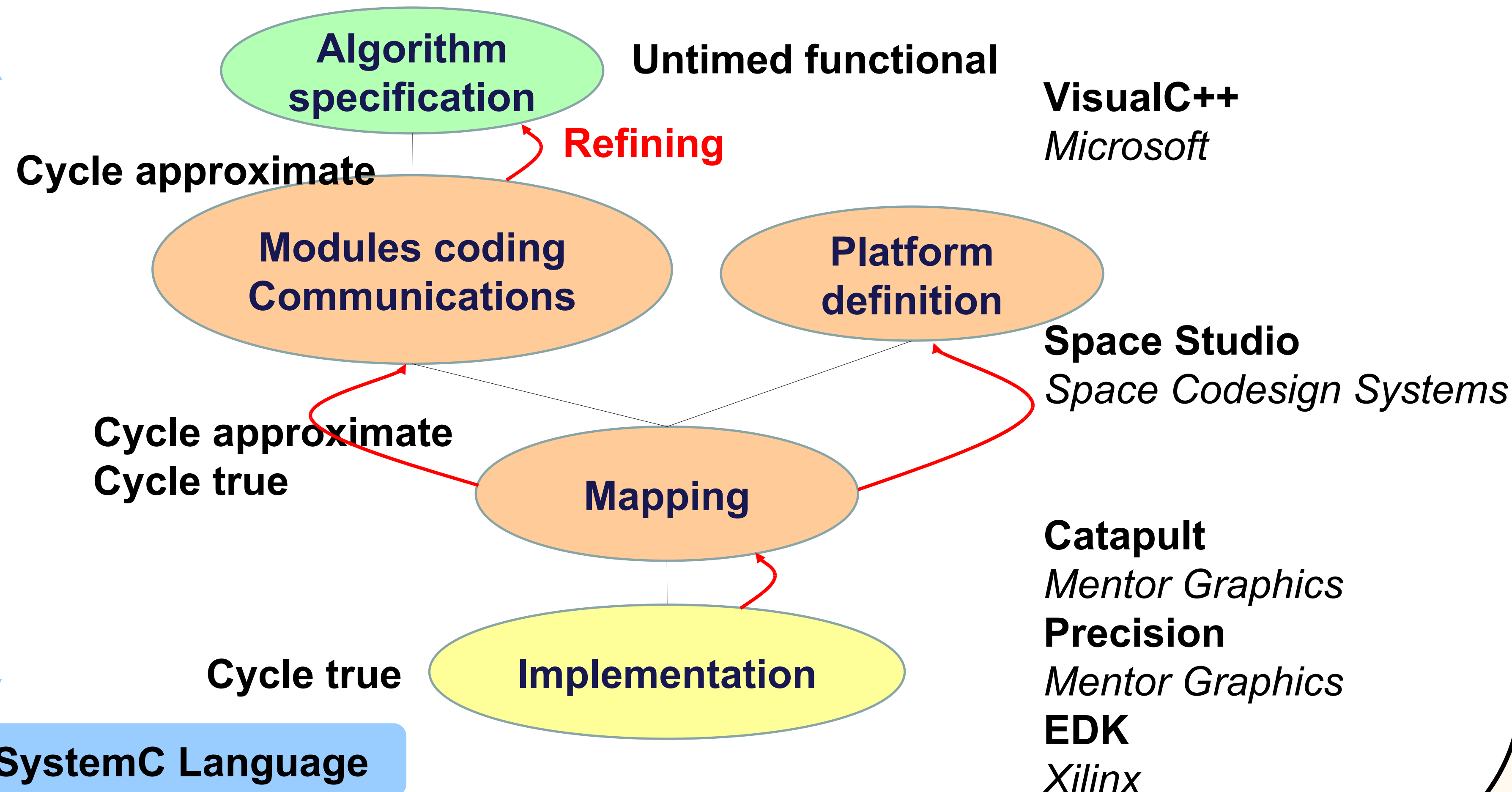

Case study

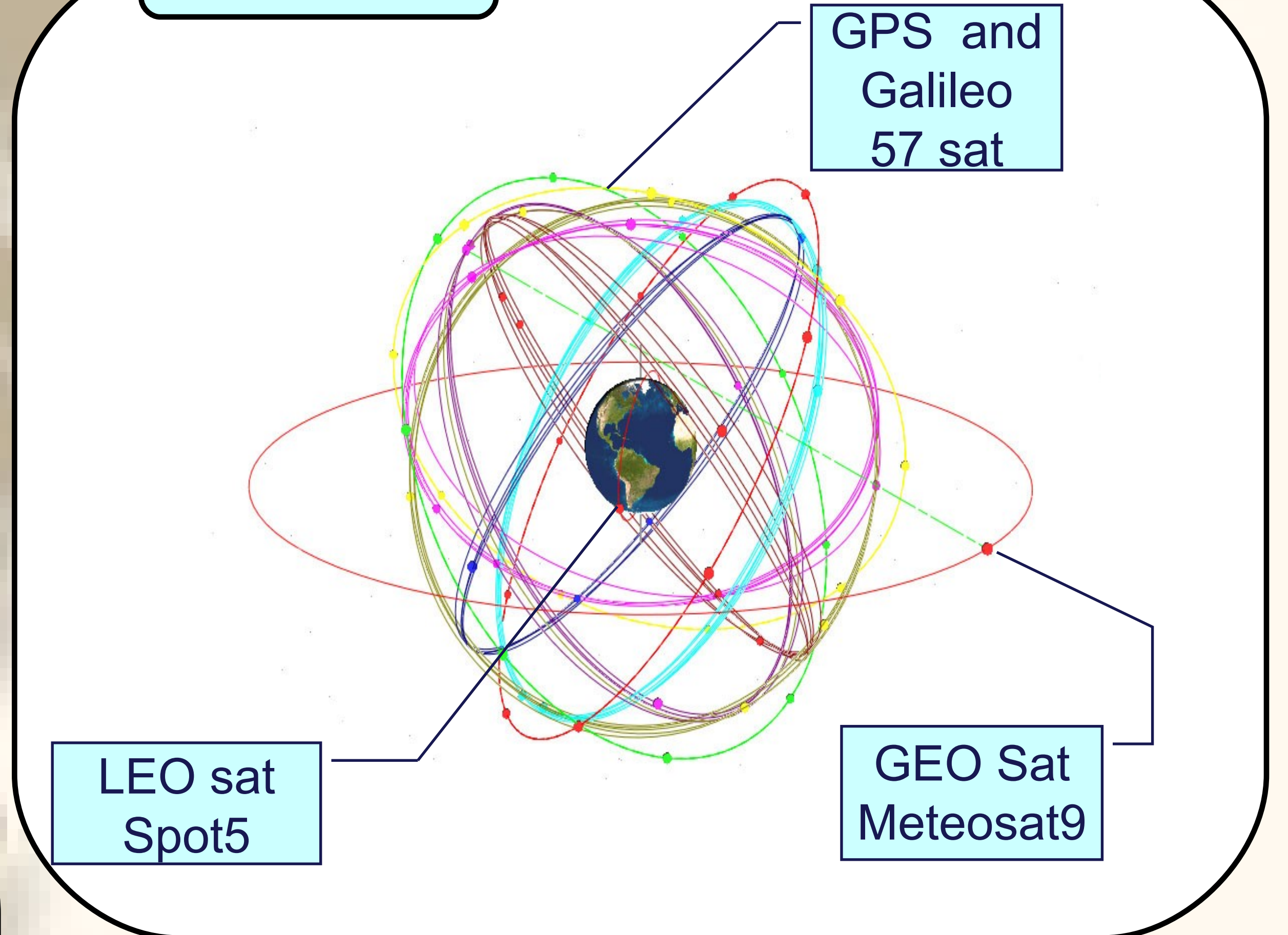

Decomposition

- Identification of the **parallelism**
- Communication
 - **synchronization**
 - Bus, direct link
- **Granularity**
 - communication interface
 - Same configuration parameters
- Approximation of the **latency**

Mapping

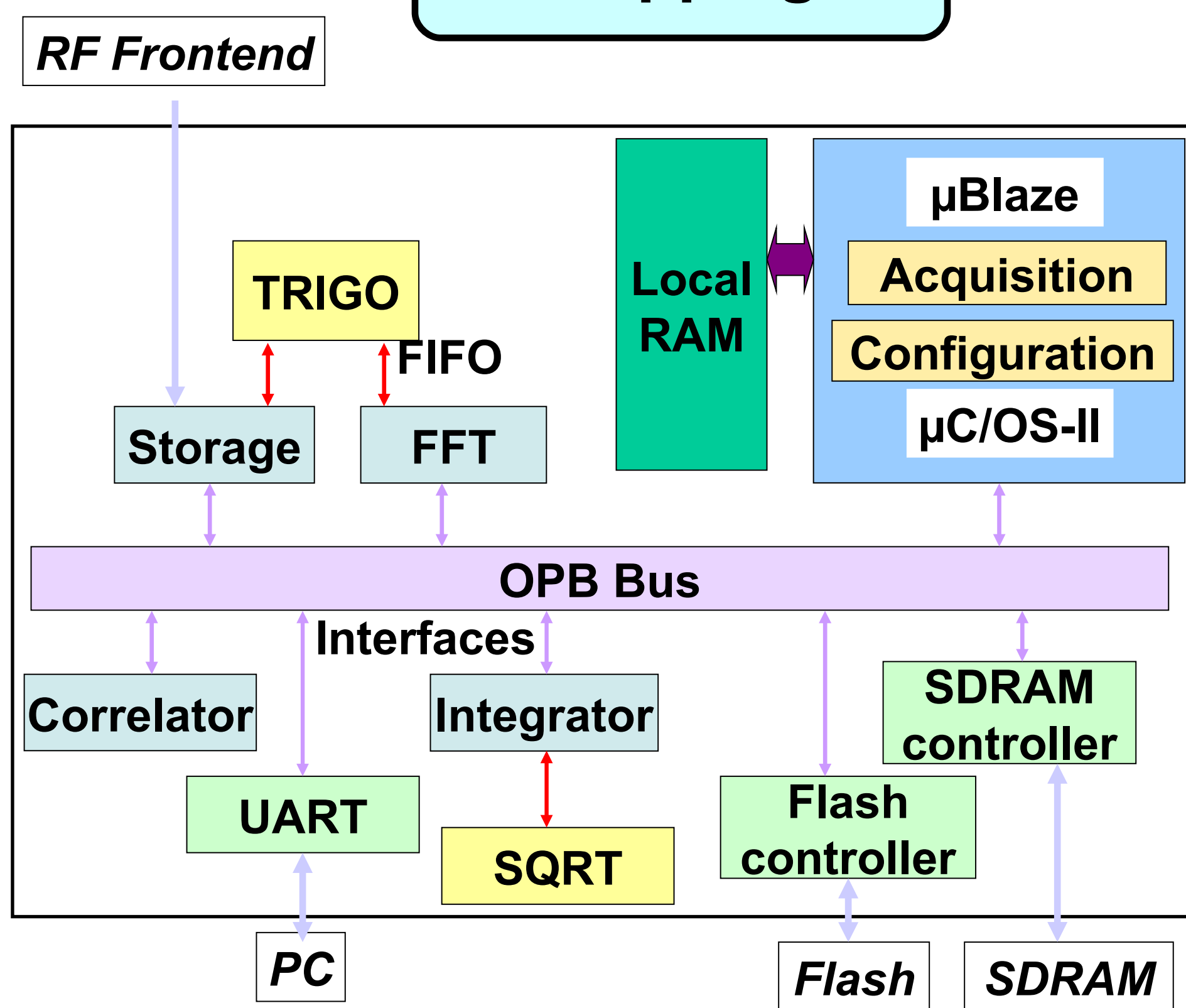

Tasks Mapping between **hardware** and **software** modules.

Interfaces and **drivers** are automatically generated for communication.

Hardware **custom IP** are still cycle approximate

Others IP are cycle true: Software IP, bus... **Simulation** of the solutions.

Resource **estimation**

Analysis

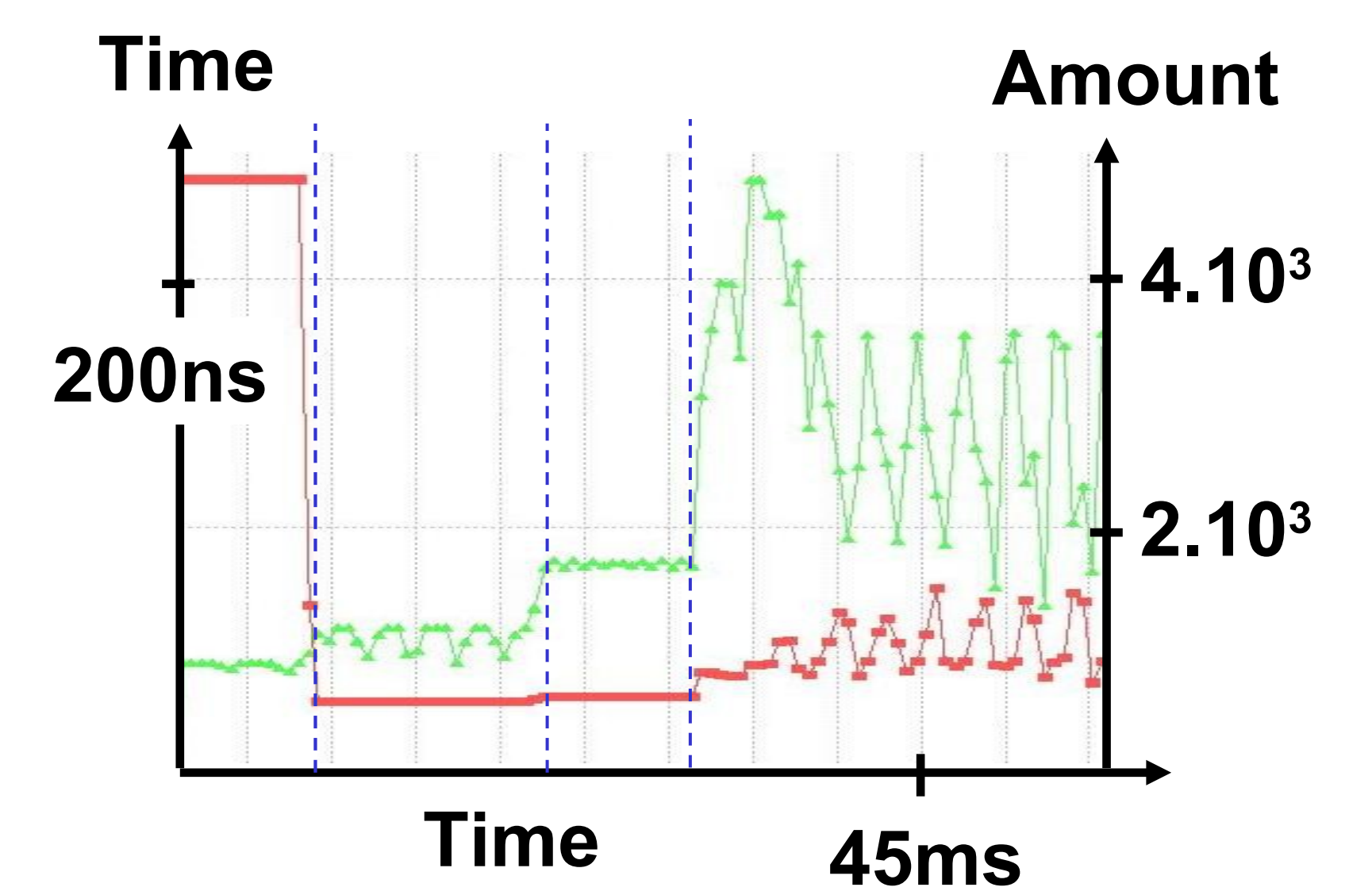

Conclusion

Design time is reduced:

Approx. 3 months

Early **simulation** of the design

Refining of the specifications, of the architecture

Need a more complete **IP library.**

Space-dedicated LEON processor, AMBA bus...

Communication protocol

Dynamic address, implementation

Results

	Slices	DFF	Mult	BRAM
Available	13696	27392	136	136
User modules	4744	4723	14	9
Interfaces	2780	2644	0	8
Platform IPs	3313	3592	3	80
Total	10837	10959	17	97

Need optimization :

- Coding style
- Catapult

4 user interfaces to OPB.

- Granularity